



S W Hart & Co ®

MAKE HART MODEL WP-2 STAGE

Weather Proof Louvre 2 Stage

FEATURES :

- ⊙ Outside air intake or exhaust louvre
- ⊙ Front horizontal blade and rear vertical blade
- ⊙ Aluminium construction
- ⊙ Standard finish clear anodized
- ⊙ Powder coat finish available on request
- ⊙ Free area - approximately 50%

ACCESSORIES :

- ⊙ Opposed Blade Damper
- ⊙ Removable Inner Core with hinging option
- ⊙ Bird Wire or Insect Mesh Screen
- ⊙ Blanking Plate
- ⊙ BAL Rated Ember Screen

INSTALLATION :

- ⊙ Exterior Wall



DIMENSION :

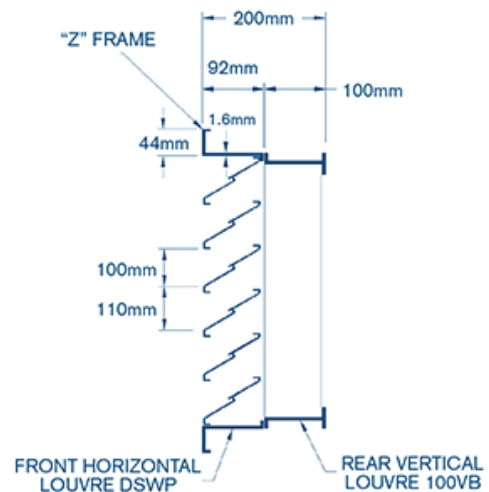

WP-2 STAGE - STANDARD SIZES :

- ⊙ Made to order

CYCLONE :

- ⊙ Can be supplied as a NATA Certified Two Stage Cyclone Proof Grille in accordance with AS/NZ 1170-2011 Part 2 - "Wind Actions" for Cat D Cyclonic Area.(Use Two Stage Selection Data)